

# Class 150 Stainless Steel Ball Valves

## Full port, Split body, Side entry design

### Features

- Antistatic device
- Blowout-proof stem
- Double "D" stem head
- High performance **HYPATITE® PTFE** ball seats

Page 8 for Pressure-Temperature Ratings

Page 43 for Construction and Materials

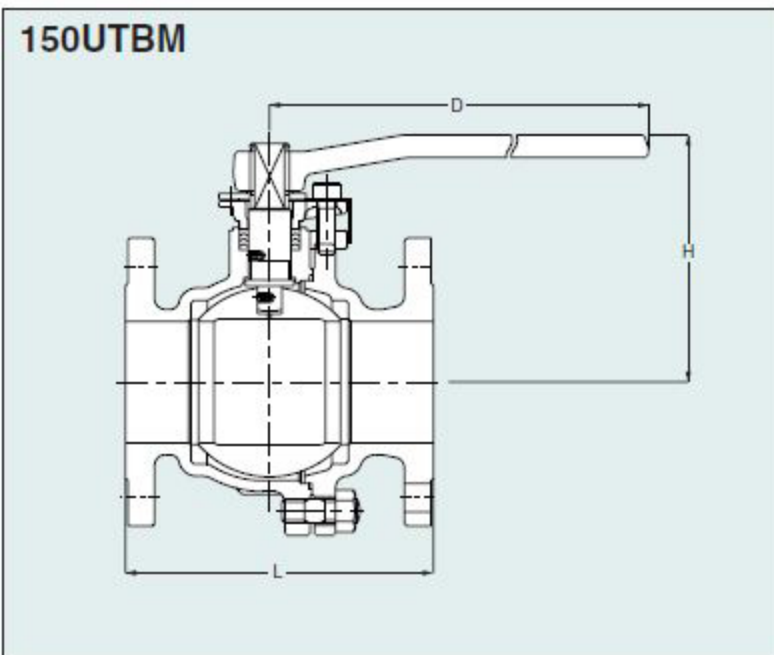

### Dimensions of 150UTBM

Unit: mm

Valve Size	In.	1/2	3/4	1	1 1/2	2	2 1/2	3	4	5	6	8	10
	mm	15	20	25	40	50	65	80	100	125	150	200	250
Ball Bore		15	20	25	40	50	65	80	100	125	150	200	250
L		108	117	127	165	178	190	203	229	356	394	457	533
H		102	105	124	115	120	155	165	200	220	295	355	Gear operation
D		130	130	160	230	230	400	400	460	460	1000	1500	Gear operation

### Valve operator

1/2"~8": Lever operation

5"~8": Optional gear operation

10": Standard gear operation