

PNEUMATIC ACTUATOR EB-SYD, DOUBLE ACTING

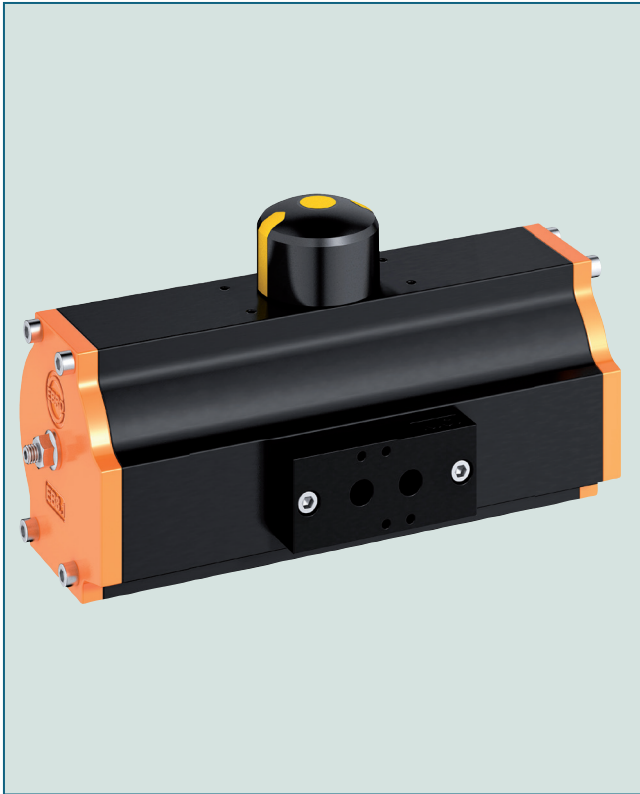

The double acting version of this series is available in 13 sizes, constructed to the scotch-yoke principle.

TECHNICAL DATA

Torque:	27 - 9768 Nm
Limit of travel:	exactly adjustable between $-8^{\circ}/+3^{\circ}$
Limit switches and solenoid valve mounting:	VDI / VDE 3845
Supply pressure:	min. 2,5 bar, max. 8 bar
Supply quality:	Filtered compressed air dry or lubricated. The pressure condensation point in accordance with (ISO 8573-1:2010, Class 3) has to be $\geq -20^{\circ}\text{C}$ or 10°C under ambient temperature. The maximum particle size in accordance with (ISO 8573-1:2010, Class 5) should not exceed 40 μm . For cycles ≥ 4 /min please lubricate.
Temperature range:	-20°C to $+80^{\circ}\text{C}$ (standard) -40°C to $+80^{\circ}\text{C}$ (low temperature) -15°C to $+120^{\circ}\text{C}$ (high temperature)
Valve interface:	EN ISO 5211
Actuator cylinder:	Anodized aluminium, Other coatings upon request.

FEATURES

- Maintenance-free
- Suitable for all $\frac{1}{4}$ turn valves
- Blow-out proofed shaft
- Torques in agreement with EN ISO 5211
- Optical position indicator with integrated operator for limit switches
- All fasteners made of stainless steel
- SIL 2 (SIL 3 as redundant system) acc. to IEC 61508

KEY BENEFITS

- High opening- and closing- torques provided by scotch-yoke concept
- Ideal sliding properties provided by low friction multiple piston guides
- Operational safety and long service life assured by precise machining of parts
- Low air consumption
- ATEX: EX II 2 GD c Tx



The EBRO Speed Control block allows the adjustment of closing/ opening times up to 60 sec. (depending on actuator size). It can be mounted directly onto the actuator.

PNEUMATIC ACTUATOR EB-SYD, DOUBLE-ACTING

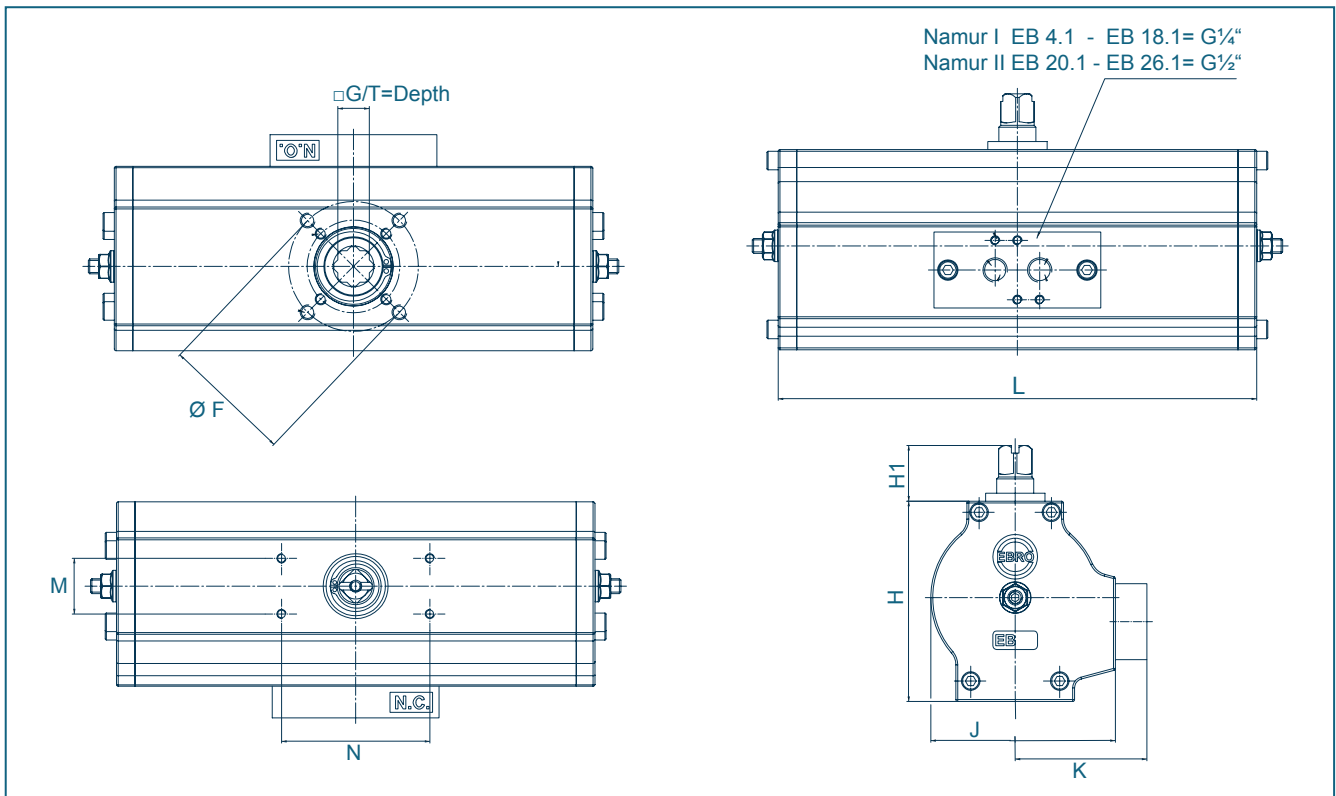

Type	ØF	G**	Dimensions [mm]								Weight [kg]
			H	H1	J	K	L	M	N	T	
EB 4.1	F04/05*	10/11/12	66	30	57	49	148	30	80	13/16	1,1
EB 5.1	F04/05*	11/12/14	77	30	72	57	174	30	80	13/16	1,7
EB 6.1	F04/05/07*	11/12/14/16/17	91	30	88	66	224	30	80	19	3,0
EB 8.1	F05/07/10***	12/14/16/17/22	108	30	100	71	258	30	80	19	4,1
EB 9.1	F07/10	14/16/17/22	120	30	113	78	311	30	80	24	6,7
EB 10.1	F07/10	14/16/17/22	129	30	122	82	334	30	80	24	7,5
EB 12.1	F10/12	17/22/24/27	156	30	145	93	392	30	80	29	12,7
EB 14.1	F12/16/25***	36	189	30	154	102	433	30	80	38	21,3
EB 16.1	F12/16/25***	46	212	30	172	102	525	30	80	48	29,0
EB 18.1	F12/16/25***	46	243	30	196	103	590	30	80	48	41,0
EB 20.1	F12/16/25***	46	272	30	234	120	611	30	80	48	57,1
EB 22.1	F16/25***	55	283	30	244	125	698	30	80	59	72,5
EB 26.1	F16/25***	55	350	30	336	168	896	30	80	59	130,2

* F04/F05 no combined flange available (Standard = BOLD)

Subject to change without notice

** Mounting flange F25

*** F25 up to 4,000 Nm transferable

CLOSING TIME AND AIR CONSUMPTION

Type	EB4.1	EB 5.1	EB 6.1	EB 8.1	EB 9.1	EB 10.1	EB 12.1	EB 14.1	EB 16.1	EB 18.1	EB 20.1	EB 22.1	EB26.1
Closing time EB-SYD in sec.*	0,25	0,25	0,35	0,45	0,55	0,70	1,00	<1,5	<1,5	<2,0	<2,0	<2,0	<2,0
Filling volume Standard liter/stroke at 1 atm:**	0,18	0,46	0,91	1,49	2,33	3,26	5,63	7,52	11,01	16,49	22,79	29,7	60,94

* closing times with unthrottled air exhaust and air supply, 6 bar control pressure at no load operation

** loadair consumption = filling volume x control

Closing-/ opening times can be adjusted up to 60 sec. by using the EBRO speed control block (depending on type of actuator).

PNEUMATIC ACTUATOR EB-SYD, DOUBLE ACTING

MATERIAL SPECIFICATION AND PARTS LIST

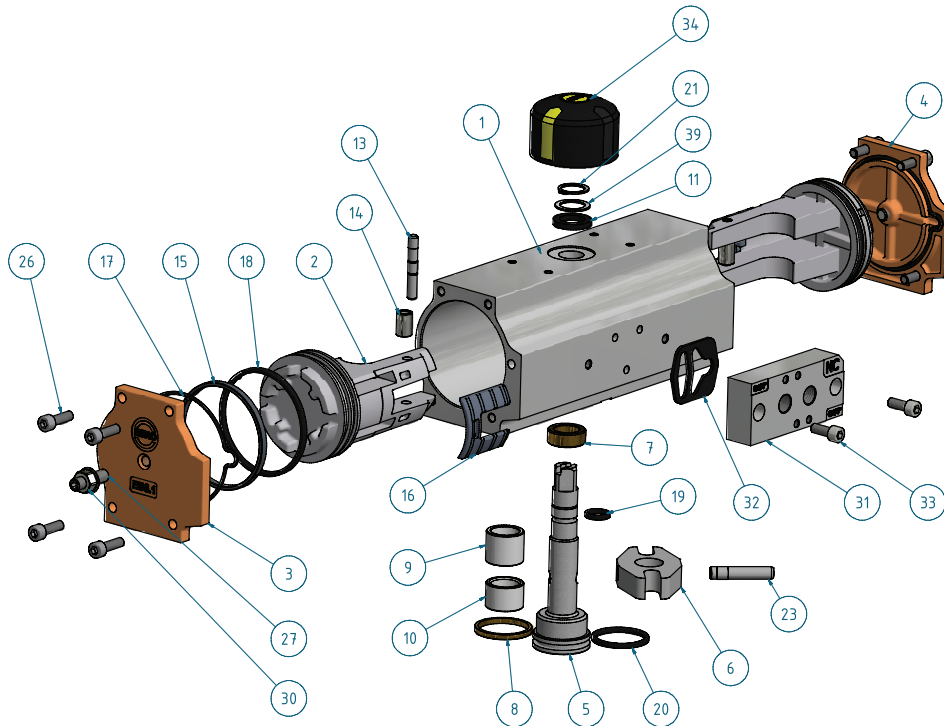

Only for EB-SYD (4.1 - 12.1)

COMPONENT PARTS

Pt.	Description	Qty.	Material	Pt.	Description	Qty.	Material
1	Actuator cylinder	1	EN AW 6063 - T6	17D	End cover sealing	2	NBR 70
2	Piston	2	EN AC 46000	18D	Piston O-Ring	2	NBR 70
3	End cover L SYD	1	EN AC 46000	19D	O-Ring, upper shaft	1	NBR 70
4	End cover R SYD	1	EN AC 46000	20D	O-Ring, lower shaft	1	NBR 70
5	Drive shaft	1	1.7131	21D	Safety ring	1	1.1248
6	Yoke	1	1.7131 / Sint - D30	23	Bolt	1	1.7225
7	Upper shaft bearing	1	Sint - B50	26	Hex. socket screw	8	A2 - 70
8	Lower shaft bearing	1	Sint - B50	27	Stroke adjusting screw	2	A2 - 70
9	Upper piston bearing	1	technical polymer	30	Seal nut	2	A2 - 70
10	Lower piston bearing	1	technical polymer	31	Valve connection plate	1	EN AC 46000
11	Washer bearing	1	technical polymer	32D	Shaped gasket	1	NBR 70
13	Piston bolt	2	1.7131	33	Hex. socket screw	2	A2 - 70
14	Roller	2	1.3505	34	Position indicator	1	technical polymer
15	Guide band	2	technical polymer	39	Washer	1	A2
16	Slidepad	2	technical polymer				

The spare parts marked with D are integrated in the standard seal set.

Subject to change without notice

PNEUMATIC ACTUATOR EB-SYD, DOUBLE ACTING

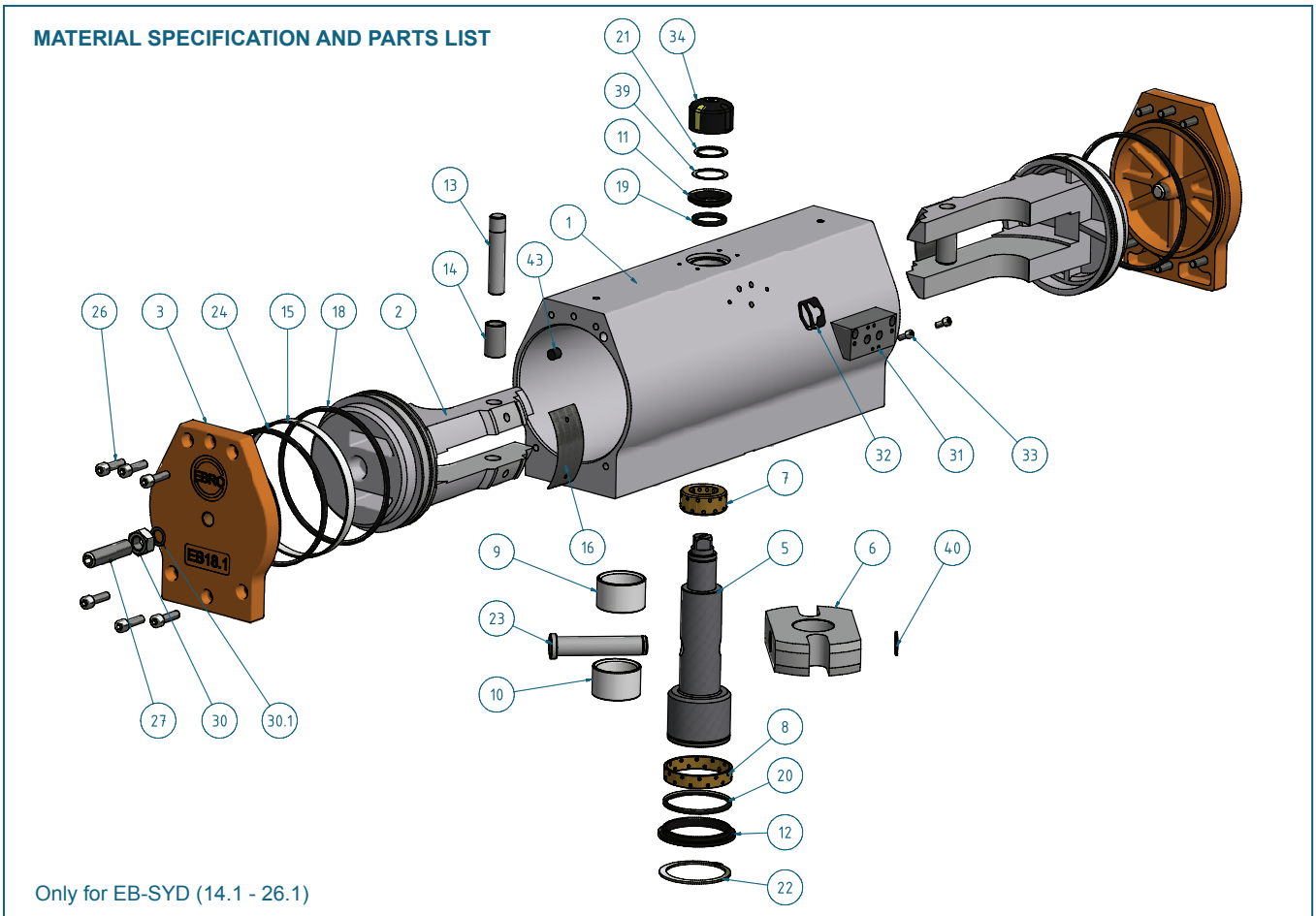

COMPONENT PARTS

Pt.	Description	Qty.	Material	Pt.	Description	Qty.	Material
1	Actuator cylinder	1	EN AW 6063 - T6	20D	O-Ring, lower shaft	1	NBR 70
2	Piston	2	EN AC 46000	21D	Upper safety ring	1	1.1248
3	End cover SYD	2	EN AC 46000	22D	Lower safety ring	1	1.1248
5	Drive shaft	1	1.7131	23	Bolt	1	1.7225
6	Yoke	1	1.7131	24D	Cover O-ring	2	NBR 70
7	Upper shaft bearing	1	MS & Graphite	26	Hex. socket screw	8/16	A2 - 70
8	Lower shaft bearing	1	MS & Graphite	27	Stroke adjusting screw	2	A2 - 70
9	Upper piston bearing	1	Technical polymer	30	Seal nut	2	A2 - 70
10	Lower piston bearing	1	Technical polymer	30.1	O-Ring	2	NBR 70
11	Upper washer bearing	1	Technical polymer	31	Valve connection plate	1	EN AC 46000
12	Lower washer bearing	1	Technical polymer	32D	Shaped gasket	1	NBR 70
13	Piston bolt	2	1.7131	33	Hex. socket screw	2	A2 - 70
14	Roller	2	1.3505	34	Position indicator	1	Technical polymer
15	Guide band	2	Technical polymer	39	Washer	1	A2
16	Slidepad	2	Technical polymer	40	Safety ring	1	1.1248
18D	Piston O-Ring	2	NBR 70	43	Sealing plugs	2	NBR 70
19D	O-Ring, upper shaft	1	NBR 70				

The spare parts marked with D are integrated in the standard seal set.

Subject to change without notice

PNEUMATIC ACTUATOR EB-SYD, DOUBLE ACTING

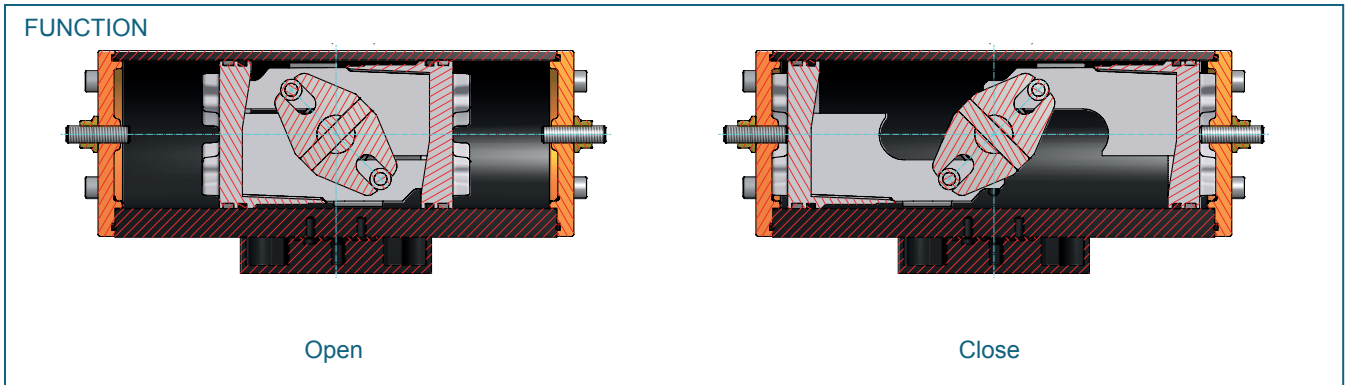

When the left control connection is pressurized, the pistons are pushed together with the yoke turning counter-clockwise to open the valve. When the right control connection is pressurized,

the yoke turns clockwise to close the valve.

The stroke of the piston can be limited by adjusting the screws located in the end covers.

TORQUE (Nm)

Type	Control pressure									
	2,5 bar	3 bar	3,5 bar	4 bar	4,5 bar	5 bar	5,5 bar	6 bar	7 bar	8 bar
EB 4.1	11	13	16	18	20	22	25	27	31	36
EB 5.1	32	38	44	51	57	63	70	76	89	101
EB 6.1	65	78	91	104	117	130	143	156	182	208
EB 8.1	104	125	146	166	187	208	229	250	292	333
EB 9.1	157	189	220	252	283	315	346	378	441	504
EB 10.1	220	265	309	353	397	441	485	530	618	706
EB 12.1	381	457	534	610	686	762	839	935	1067	1220
EB 14.1	557	668	780	891	1002	1114	1226	1337	1560	1782
EB 16.1	846	1011	1180	1348	1517	1685	1854	2022	2359	2696
EB 18.1	1098	1317	1537	1756	1976	2195	2415	2634	3073	3512
EB 20.1	1541	1850	2158	2466	2775	3082	3391	3700	4316	4932
EB 22.1	2125	2550	2975	3400	3825	4250	4675	5100	5950	6800
EB 26.1	4070	4884	5698	6512	7326	8140	8954	9768	11396	13024

Subject to change without notice

The torques shown in the diagram are measured values. The required size of the actuator can be established by comparing the values of the actuator with the required torque of the valve.

Especially non-lubricant media (e.g. bulk goods and dry gases) may cause an increase of the valve torque. Choosing an actuator in critical limits, please contact our engineers.

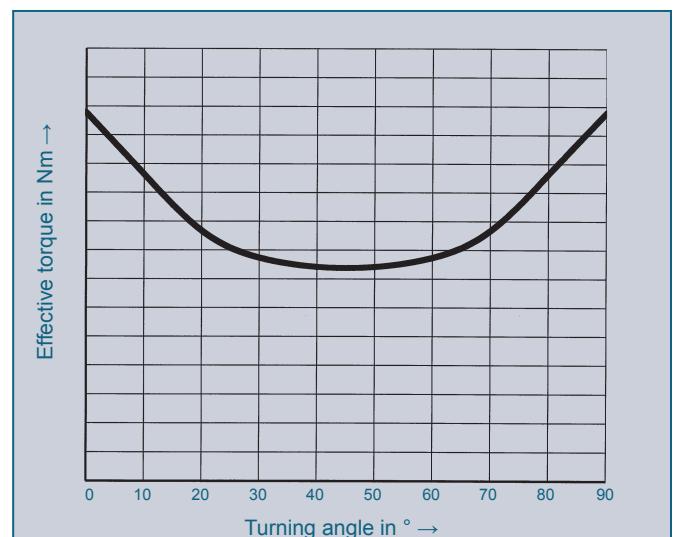

Typical torque curve of a scotch-yoke actuator.

