

GP-1000EN - 1000HEN

Features

1. Both GP-1000EN and GP-1000HEN can be replaced easily from existing valve because it complies with face-to-face dimensions of the EN standard.
2. Respond very sharply to the fluctuation of inlet pressure and the change of the flow rate, so that the reduced pressure can be kept at a constant level.
3. Pressure adjustment is easy, and the set pressure range is wide.
4. Compliant with the standard of SHASE-S106 Pressure Reducing Valves (by the Society of Heating, Air-Conditioning and Sanitary Engineers of Japan).

Specifications

Model	GP-1000EN	GP-1000HEN
Application	Steam	
Inlet pressure	0.1-1.0 MPa	0.1-1.6 MPa
Reduced pressure	0.05-0.9 MPa	(A) 0.05-0.9 MPa (B) 0.9-1.4 MPa
	90% or less of inlet pressure (gauge pressure)	
Minimum differential pressure	0.05 MPa	
Maximum pressure reduction ratio	20:1	
Maximum temperature	220°C	
Valve seat leakage	0.01% or less of rated flow rate	
Material	Body	Ductile cast iron
	Main valve, valve seat	Stainless steel
	Pilot valve, pilot valve seat	Stainless steel
	Piston, cylinder	Brass and bronze
	Diaphragm	Stainless steel
Connection	EN PN16	EN PN25



GP-1000HEN

Dimensions (mm) and Weights (kg)

Nominal size	L	H	H1	Weight
15A	150	291	64	8.0
20A	150	291	64	8.5
25A	160	300	67	10.0
32A	180	333	82	14.0
40A	200	333	82	15.5
50A	230	353	93	21.0
65A	290	357	100	30.0
80A	310	404	122	37.0
100A	350	450	144	57.0

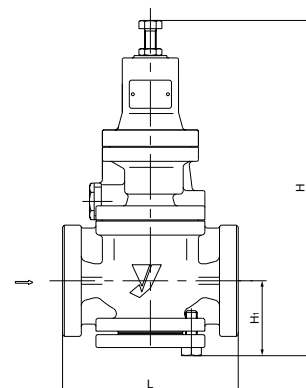

Specifications Selection Chart

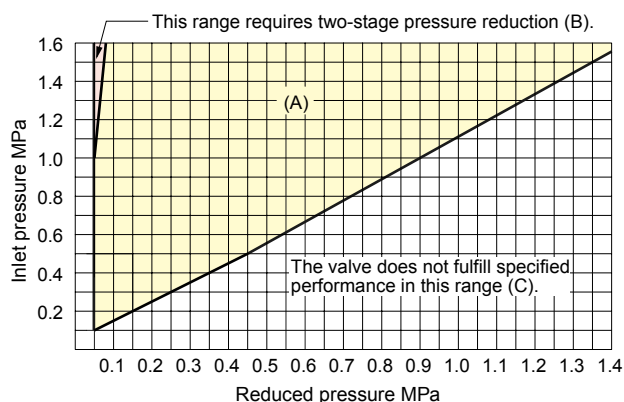

Find the intersection point of the inlet and reduced pressures. If the intersection point is within range (A) in the chart, the pressures are controllable with a single pressure reducing valve. They can be controlled by two-stage pressure reduction if the intersection point is within range (B). The valve does not fulfill specified performance in range (C).

Table of Corrected Cv Values

● Table of rated Cv values (Cv value when the correction factor C = 1)

Nominal size	15A	20A	25A	32A	40A	50A	65A	80A	100A
Cv values	1	2.3	4	6.5	9	16	25	36	64

Note) When the reduced pressure is within either of the ranges shown below, calculate the corrected Cv value by multiplying the rated Cv value by the correction factor C obtained from the Fig.1.

- When the inlet pressure is between 0.7 MPa and 1.0 MPa and the pressure reduction ratio is more than 10:1
- When the inlet pressure is more than 1.0 MPa and the reduced pressure is 0.4 MPa or less

Nominal Sizes Selection Chart (For Steam)

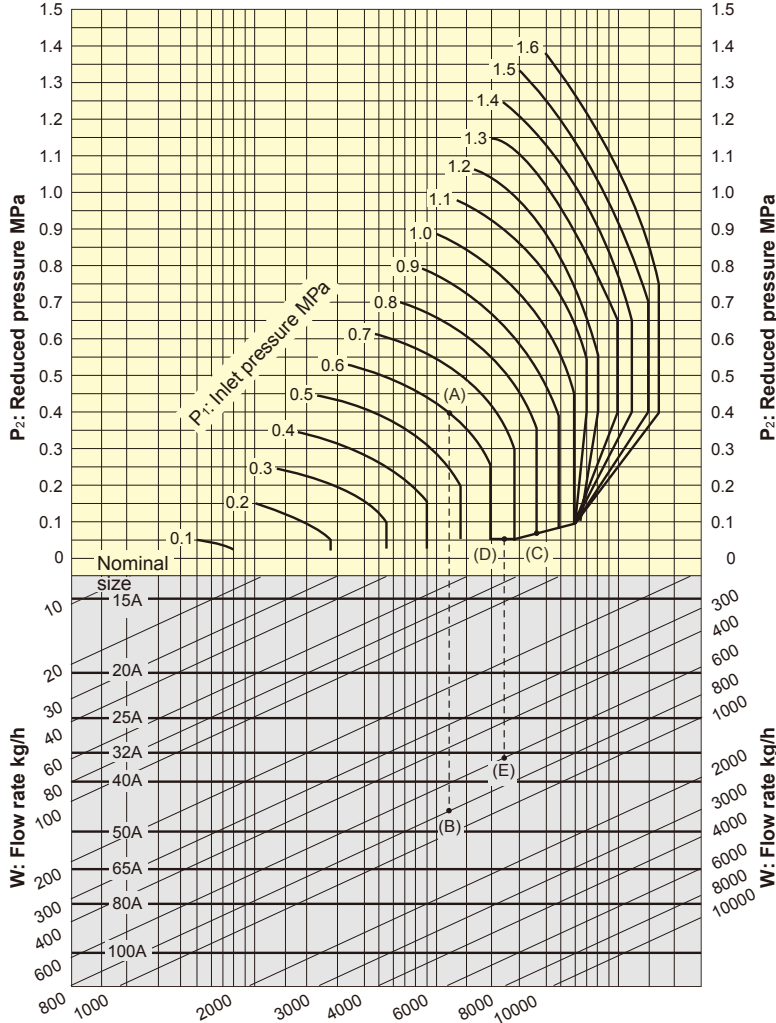

[Example 1]

When selecting the nominal size of a pressure reducing valve whose inlet pressure (P_1), reduced pressure (P_2), and steam flow rate are 0.6 MPa, 0.4 MPa, and 800 kg/h, respectively, first find intersection point (A) of the inlet pressure of 0.6 MPa and the reduced pressure of 0.4 MPa. Trace down vertically from this intersection point to find intersection point (B) with the flow rate of 800 kg/h. Since intersection point (B) lies between nominal sizes 40A and 50A, select the larger one, 50A.

[Example 2]

When selecting the nominal size of a pressure reducing valve whose inlet pressure (P_1), reduced pressure (P_2), and steam flow rate are 0.8 MPa, 0.05 MPa, and 600 kg/h, respectively, first find intersection point (C) of the inlet pressure of 0.8 MPa and the diagonal line. Trace down to the left from this diagonal line to find intersection point (D) with the reduced pressure of 0.05 MPa. Trace down vertically from intersection point (D) to find intersection point (E) with the flow rate of 600 kg/h. Since intersection point (E) lies between nominal sizes 32A and 40A, select the larger one, 40A.

- Set the safety factor at 80 to 90%.

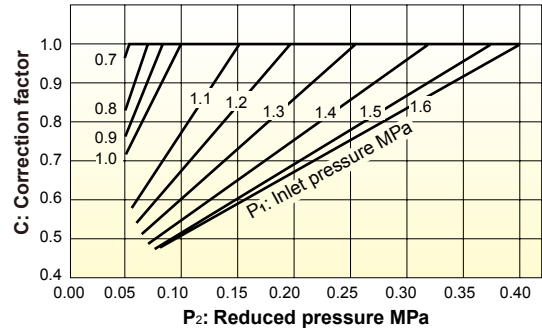
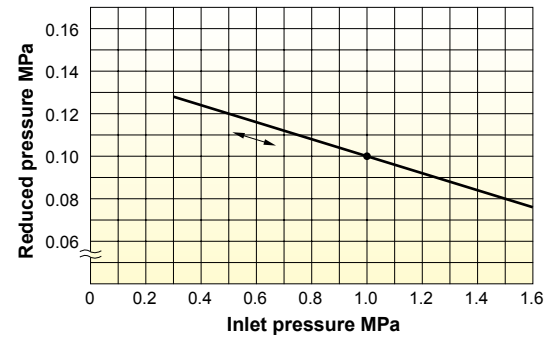

Fig. 1: Corrected Cv value

Pressure Characteristic Chart



This chart shows variation in reduced pressure when the inlet pressure of 1.0 MPa is changed between 0.3 MPa and 1.6 MPa while the reduced pressure is set at 0.1 MPa.

Flow Characteristic Chart

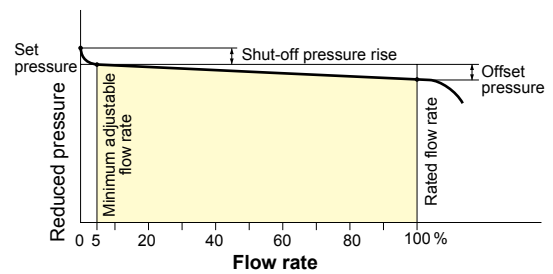

- Shut-off pressure rise: Within 0.02 MPa
- Offset pressure: Within 0.03 MPa
(when the set pressure is between 0.05 MPa and 0.1 MPa)
Within 0.05 MPa
(when the set pressure is more than 0.1 MPa and 1.4 MPa or less)

INTERNATIONAL DEPT.

955-5 Miyamae, Irukadeshinden, Komaki, Aichi, 485-0084, Japan
Phone: 81-568-75-4432 Fax: 81-568-75-4763 E-mail: intntl@yoshitake.co.jp

YWT SALES DIV.

222 Moo.3 T.Banbung A.Banbung Chonburi 20170, Thailand
Phone: 66-038-110-003 Fax: 66-038-110-012 E-mail: intntl@yoshitake.co.jp

YOSHITAKE

<http://www.yoshitake.jp>